

Specifications

Output Power HP (kW)	1/4 (0.2)
Phase	3 Phase
Pole	6 Pole
Frame Number	71M

Degrees of Protection	IP 55
Enclosure Construction	Totally-enclosed Fan-cooled
Thermal Class	Class F (155 °C)

Alignment	Horizontal
Frame Material	Steel plate

Power Transmission	Direct-couple or Belt Driven
Direction of Rotation	Counterclockwise (CCW) viewed from shaft-end side

Connection Type	Terminal Block (6 Leads)
Coating Colour	Munsell N5.5 (Gray)
Conformed Standard	IEC 60034-1 & JEC-2137-2000

Voltage & Frequency	LT Type
	220/380~415V 50Hz 220/440V 60Hz

Motor Characteristics

Type	Hz	V	50% Load			75% Load			100% Load				Torque(%)		Is (A)	Inertia GD ² (kg-m ²)	
			(A)	Eff(%)	PF(%)	(A)	Eff(%)	PF(%)	(A)	Eff(%)	PF(%)	Speed (r/min)	Torque (kg-m)	Ts			Tm
LT	50	220	0.92	0.62	0.46	1.01	0.67	0.58	1.14	0.69	0.67	920	0.21	277	247	4.50	0.0061
		380	0.53	0.62	0.46	0.58	0.68	0.58	0.66	0.69	0.67	920	0.21	277	247	2.60	
		415	0.59	0.59	0.40	0.63	0.65	0.51	0.68	0.68	0.60	930	0.21	333	296	2.81	
	60	220	0.81	0.64	0.51	0.91	0.69	0.63	1.06	0.70	0.71	1100	0.18	235	213	4.16	
		440	0.51	0.58	0.44	0.55	0.65	0.55	0.60	0.68	0.64	1120	0.17	319	291	2.76	

* The perpendicular variation of tolerance for the shaft center is $\frac{0}{-0.5}$

Dimensions (mm)

Motor													
A	B	C*	D	E	F	G	H	L	M	N	X	XB	Z
128.5	83	71	147.6	56	45	3.2	144.8	248.5	148	110	18	45	7

Terminal Box					Shaft End						
KA	KG	KD	KL	KP**	Q	QK	R	S	T	U	W
44.5	67	PF 1/2	140	161	30	25	120	14 j6	5	3	5

Bearing No.		Approximated Weight (kg)	Approximated Packing Dimensions (LxWxH)	Gross Weight (kg)
Drive End	Opposite			
6202ZZ	6201ZZ	7.4	275 x 256 x 180	8

** This dimension is for model that KP > H only

Connection & Connection Diagram

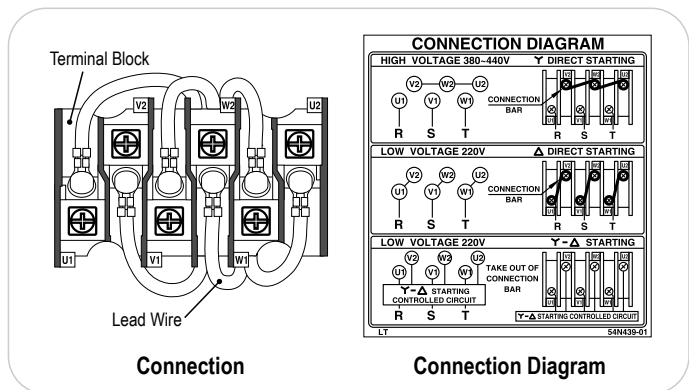

Circumstance Conditions

Ambient Temperature	-20 ~ +40°C
Ambient Humidity	95% RH or less
Operating Altitude	Less than 1,000m above sea level
Environment	No bursting / erosive gas or vapor